

Roller guide

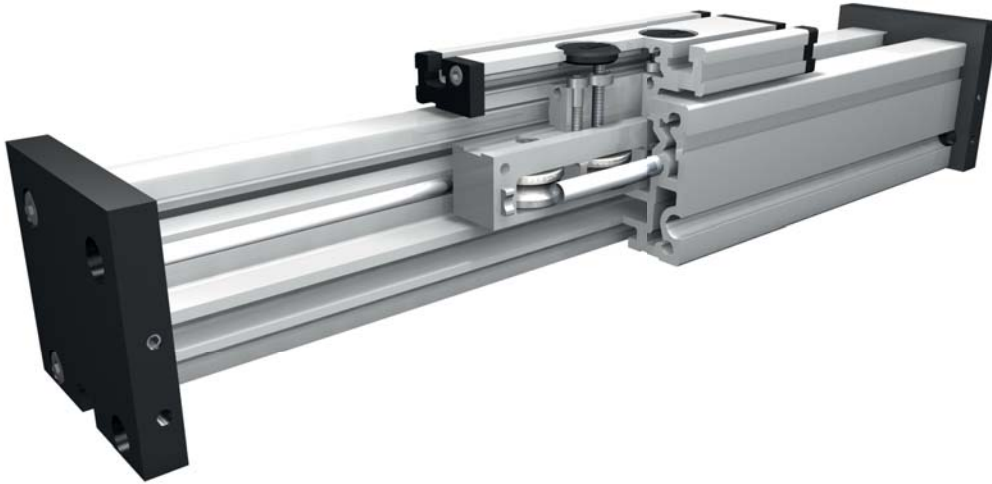

5.1

Function:

This unit consists of a square aluminium profile with an integrated roller guide. The carriage, which has internal linear ball bearings that can be adjusted free of play, moves along the guide body. This roller guide can be driven by a pneumatic cylinder or other additional drives or it serves as a load carrying slide unit.

Fitting position:

As required. Max. length 6.000 mm without joints.

Carriage mounting:

By T-slots.

Unit mounting:

By T-slots and mounting sets. The linear axis can be combined with any T-slot profile.

Carriage support:

In the standard version, the carriage runs on 4 rollers which can be adjusted and serviced at a central servicing position. For longer carriages the number of rollers can be increased.

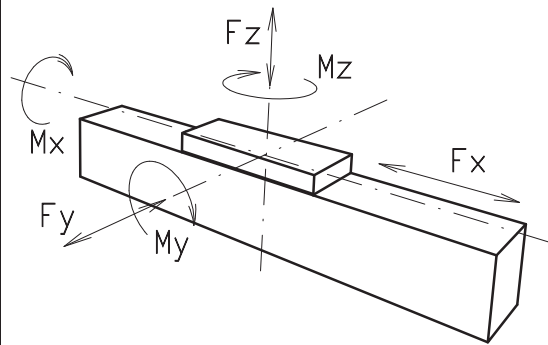
Forces and torques

Size	60		80		100	
Forces/torques	static	dynamic	static	dynamic	static	dynamic
F_x (N)	-	-	-	-	-	-
F_y (N)	600	500	1600	1240	1900	1500
F_z (N)	900	650	1500	1200	2100	1700
M_x (Nm)	15	10	50	40	85	60
M_y (Nm)	60	50	100	80	140	110
M_z (Nm)	40	30	75	60	110	90
All forces and torques related to the following:						
existing values	$\frac{F_y}{F_{y_{dyn}}} + \frac{F_z}{F_{z_{dyn}}} + \frac{M_x}{M_{x_{dyn}}} + \frac{M_y}{M_{y_{dyn}}} + \frac{M_z}{M_{z_{dyn}}} \leq 1$					
table values						
Speed						
(m/sec) max	4		6		7	
Geometrical moments of inertia of aluminium profile						
I_x mm ⁴	4,3x10 ⁵		16,5x10 ⁵		43,0x10 ⁵	
I_y mm ⁴	4,8x10 ⁵		18,7x10 ⁵		48,8x10 ⁵	
Elastic modulus N/mm ²	70000		70000		70000	

For life-time calculation of rollers use our CD-ROM or homepage!

Formula: QLR

$$f = \frac{F \cdot L^3}{E \cdot I \cdot 192}$$

f = deflection (mm)
 F = load (N)
 L = free length (mm)
 E = elastic modulus 70000 (N/mm²)
 I = second moment of area (mm⁴)

Positioning system QLR 60, 80, 100

Dimensions (mm)

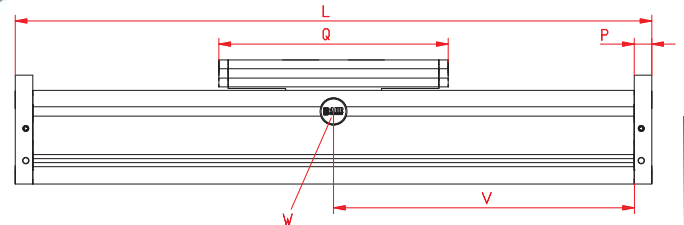
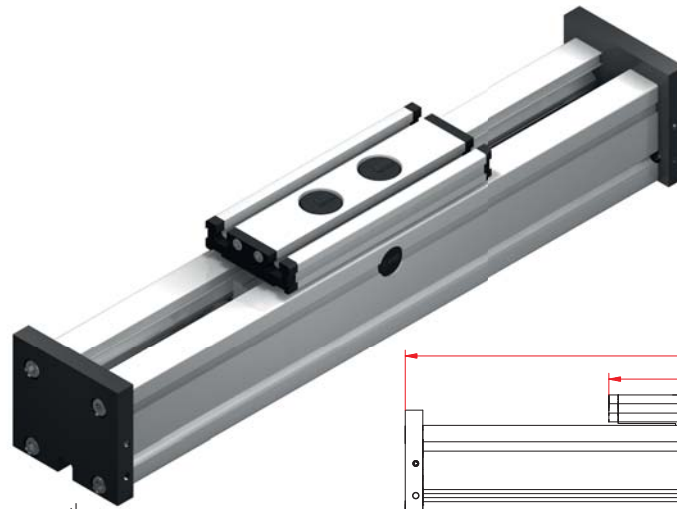
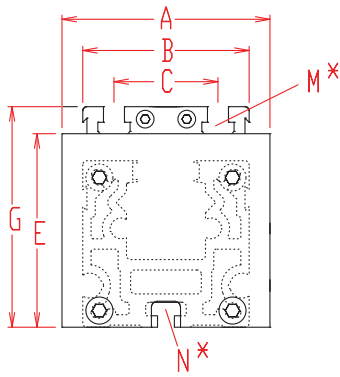

Increasing the carriage length will increase the basic length by the same amount.

*For slide nuts refer to chapter 2.2 page 2

$$V = Q + 100 \text{ mm}$$

W = servicing position

Size □	Basic length L	A	B	C	E	G	N for	M for	P	Q	Basic weight	Weight per 100 mm
QLR 60	180	80	60	36	60	79	M 5	M 6	12	152	1,45 kg	0,36 kg
QLR 80	240	100	80	50	93	106	M 6	M 8	17	196	4,2 kg	0,75 kg
QLR 100	310	130	100	66	110	129	M 10	M 10	20	260	7,2 kg	1,42 kg



Choice of body profile:

- 0** (0) Standard (1) stainless guide rods (2) stainless guide rods and screws (3) stainless guide rods, rollers and screws

Choice of carriages:

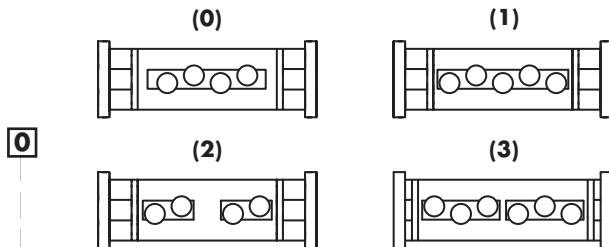

Size	Version 0		Version 1		Version 2		Version 3	
	Q	L	Q	L	Q	L	Q	L
60	152	180	192	220	>232	>260	>232	>260
80	196	240	246	290	>296	>340	>296	>340
100	260	310	320	370	>388	>430	>388	>430

1500 Basic length + stroke = total length

For additional accessories refer to chapter 2.2 – 4.2

QLR 80 0 0 0 0 0 0 0 0 1500
Pos. 1 2 3 4 5 6 7

Sample ordering code:
QLR80 with standard body profile, standard carriage and 1260 mm stroke

