

Positioning system ER 30, 40, 60, 60S, 80, 80S, 100, 125

Roller guide unit without drive

Dimensions (mm)

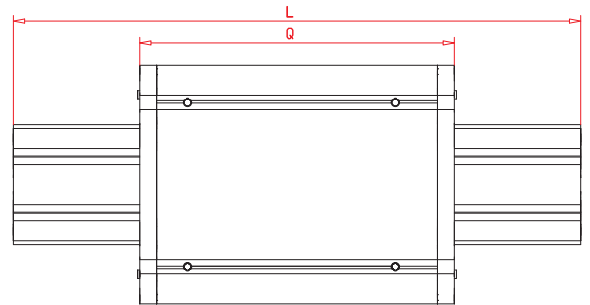
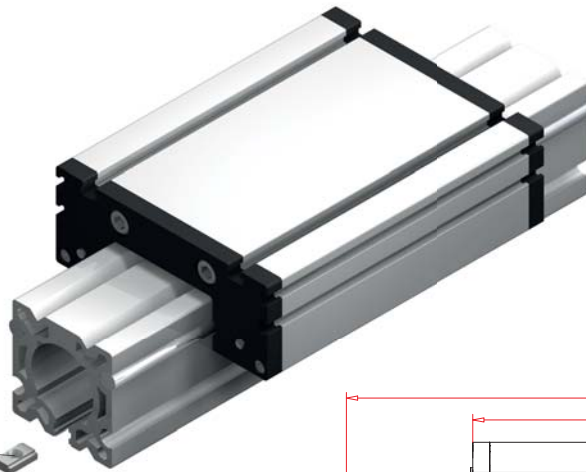
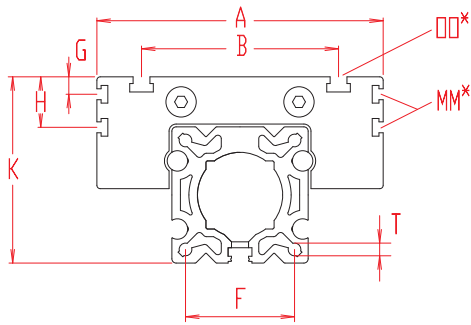

Increasing the carriage length will increase the basic length by the same amount.

*For slide nuts refer to chapter 2.2 page 2

Size □	Basic length L	A	B	F	G	H	J	K	MM for	OO for	Q	T	Basic weight	Weight per 100 mm
ER 30	86	70	56	23	-	-	M 6	41	-	M 6	82	M 4	0,5 kg	0,12 kg
ER 40	126	100	66	29	-	-	M 6 - M10	55	-	M 6	122	M 5	0,7 kg	0,23 kg
ER 60	172	144	96	48	-	-	M 6 - M10	79	-	M 8	168	M 6	2,4 kg	0,61 kg
ER 60S	198	170	108	48	-	-	M 6 - M10	83	-	M 8	194	M 6	3,4 kg	0,61 kg
ER 80	198	170	117	64	10	30	M 6 - M10	110	M 6	M 10	194	M 8	3,7 kg	0,90 kg
ER 80S	218	190	126	64	12,5	30	M 6 - M10	111	M 6	M 8	214	M 8	4,7 kg	0,90 kg
ER 100	304	230	155	80	-	29	M 10	139	M 10	M 10	300	M 10	10,8 kg	1,50 kg
ER 125	369	295	200	100	-	30	M 12	170	M 10	M 12	365	M 12	20,3 kg	2,05 kg

Choice of guide body profile:

- (0) Standard (1) stainless guide rods (2) stainless guide rods and screws (3) stainless guide rods, rollers and screws

Choice of carriages:

- (0)



- (1)



Size	Version 1	
	Q	L
30	94	98
40	138	142
60	184	188
60S	214	218
80	210	214
80S	234	238
100	316	320
125	389	393

Application:

This unit can be used as a load-carrying linear slide, or it may be fitted with a suitable pneumatic drive.

1500 Basic length + stroke = total length

ER 40 0 0 0 0 0 0 0 0 01500
Pos. 1 2 3 4 5 6 7

For combination kits and connecting elements refer to chapter 2.2

Sample ordering code:

ER 40, Non driven system, standard body profile, standard carriage, 1374 mm stroke

