

# Positioning system ELR 30, 40, 60, 60S, 80, 80S, 100, 125

Roller guide unit without drive

Specifications



## Function:

This unit consists of an aluminium hollow section with integral, parallel ground and hardened steel guide rods. The carriage has play-adjustable ball bearing rollers which engage with the guide rods. Two bearing blocks without bearings are fitted. Actuation can be by pneumatic cylinder or other device, or the unit may be used as load-carrying linear slide.

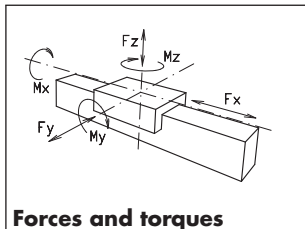

Forces and torques

## Fitting position:

As required, max. length 6.000 mm

## Carriage connection:

By T-slots and tapped holes

## Unit mounting:

By T-slots and tapped holes in the mounting surface, mounting sets.

Size	ELR 30		ELR 40		ELR 60		ELR 60 S		ELR 80		ELR 80S		ELR 100		ELR 125	
	static	dynam.	static	dynam.	static	dynam.	static	dynam.	static	dynam.	static	dynam.	static	dynam.	static	dynam.
$F_x$ (N)	-	-	-	-	-	-	-	-	-	-	-	-	-	-	-	-
$F_y$ (N)	90	60	1200	700	3000	2000	4100	3100	3000	2000	4600	3600	8000	6500	12000	9000
$F_z$ (N)	90	60	900	650	1700	1100	2160	1600	1700	1100	3000	1800	3600	2200	6000	4500
$M_x$ (Nm)	10	5	25	20	67	43	88	65	90	55	170	140	300	230	600	450
$M_y$ (Nm)	13	6	32	18	90	70	190	140	110	80	270	230	400	270	750	600
$M_z$ (Nm)	14	7	35	25	120	100	230	170	150	120	300	220	750	500	1350	1150

## All forces and torques relate to the following:

$$\text{existing values} \quad \frac{F_y}{F_{y_{dyn}}} + \frac{F_z}{F_{z_{dyn}}} + \frac{M_x}{M_{x_{dyn}}} + \frac{M_y}{M_{y_{dyn}}} + \frac{M_z}{M_{z_{dyn}}} \leq 1$$

## No-load torque

max. (m/s)	3	4	5	5	6	8	10	10

## Geometrical moments of inertia of aluminium profile

$I_x$ mm <sup>4</sup>	4,09x10 <sup>4</sup>	1,32x10 <sup>5</sup>	6,79x10 <sup>5</sup>	6,79x10 <sup>5</sup>	18,99x10 <sup>5</sup>	18,99x10 <sup>5</sup>	44,4x10 <sup>5</sup>	10,2x10 <sup>6</sup>
$I_y$ mm <sup>4</sup>	4,00x10 <sup>4</sup>	1,34x10 <sup>5</sup>	6,97x10 <sup>5</sup>	6,97x10 <sup>5</sup>	18,97x10 <sup>5</sup>	18,97x10 <sup>5</sup>	44,8x10 <sup>5</sup>	10,2x10 <sup>6</sup>
E-Modulus N/mm <sup>2</sup>	70000	70000	70000	70000	70000	70000	70000	70000

For life-time calculation of rollers use our CD-ROM or homepage!

## Formula: ELR

$$f = \frac{F \cdot l^3}{E \cdot I \cdot 192}$$

$f$  = deflection (mm)  
 $F$  = load (N)  
 $l$  = free length (mm)  
 $E$  = elastic modulus 70000 (N/mm<sup>2</sup>)  
 $I$  = second moment of area (mm<sup>4</sup>)

# Positioning system ELR 30, 40, 60, 60S, 80, 80S, 100, 125

Dimensions (mm)

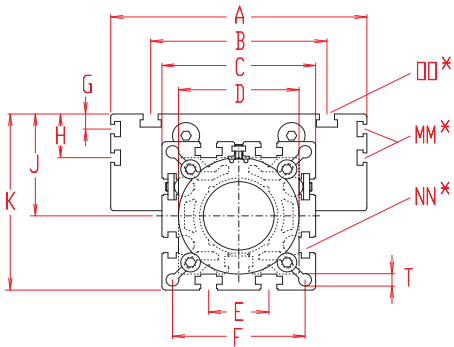

Increasing the carriage length will increase the basic length by the same amount.

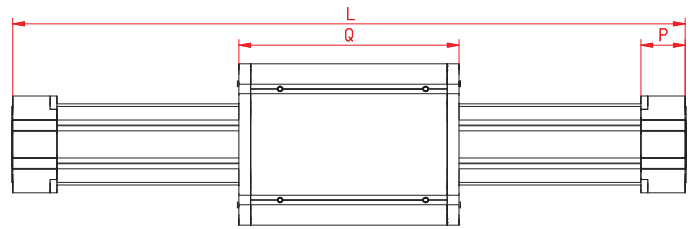
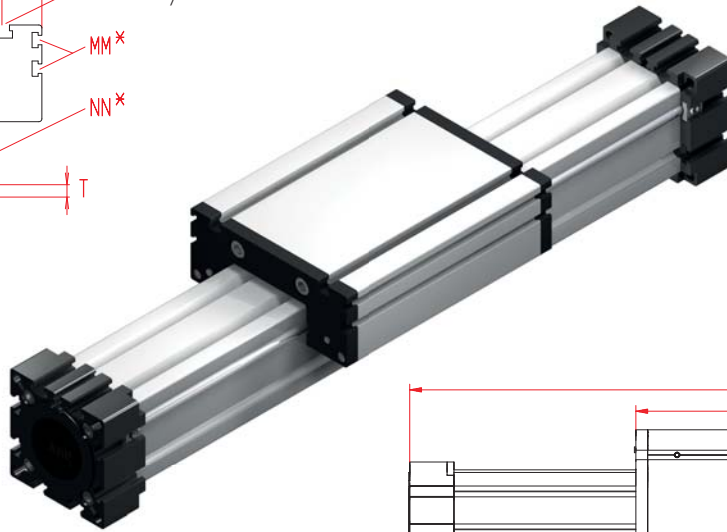

\*For slide nuts refer to chapter 2.2 page 2

Size □	Basic length L	A	B	C	D	E	F	G	H	K	MM for	NN for	OO for	P	Q	T	Basic weight	Weight per 100 mm
ELR 30	120	70	56	42	40x1	13	35	-	-	47	-	M 6	M 6	18	82	4,2	0,5 kg	0,12 kg
ELR 40	175	100	66	58	48x1	18	47	-	-	64	-	M 6	M 6	25	122	6,5	0,9 kg	0,23 kg
ELR 60	245	144	96	82	62x1	30	69	-	-	90	-	M 8	M 8	35	168	8,5	3,1 kg	0,61 kg
ELR 60S	265	170	108	82	62x1	30	69	-	-	94	-	M 8	M 8	35	194	8,5	4,1 kg	0,61 kg
ELR 80	285	170	117	102	80x1	40	88	10	30	121	M 6	M 10	M 10	45	194	8,5	5,3 kg	0,90 kg
ELR 80S	305	190	126	102	80x1	40	88	12,5	30	122	M 6	M 10	M 8	45	214	8,5	6,3 kg	0,90 kg
ELR 100	410	230	155	130	110x1	50	112	-	29	154	M 10	M 10	M 10	55	300	10,5	15,1 kg	1,50 kg
ELR 125	510	295	200	165	130x1	60	142	-	30	190	M 10	M 12	M 12	65	365	13	26,8 kg	2,05 kg

### Choice of guide body profile:

- 0** (0) Standard (1) stainless guide rods (2) stainless guide rods and screws (3) stainless guide rods, rollers and screws

### Choice of carriages:

- 0** (0)



- (1)



Size	Version 1	
	Q	L
30	94	132
40	138	191
60	184	261
60S	214	284
80	210	301
80S	234	325
100	316	426
125	389	534

**1500**

Basic length + stroke = total length

ELR 40 0 0 0 0 0 0 0 0 01500

Pos. 1 2 3 4 5 6 7

For combination kits and connecting elements refer to chapter 2.2

Sample ordering code:  
ELR 40, non driven system, standard body profile, standard carriage, 1325 mm stroke

