

Positioning system DSR 120, 160, 200

Roller unit without drive



Function:

This unit consists of a rectangular aluminium profile with 2 integrated rail guides. The openings of the guide body are sealed with 3 stainless steel cover bands to protect the guide from splash water and dust. Alternatively, the opening can also be covered with a bellow or can be delivered without cover bands. The positioning system can be either driven by an internal pneumatic cylinder or other additional drives or it serves as load carrying linear slide.

Fitting position: As required. Max. length 6.000 mm without joints.

Carriage mounting: By T-slots.

Unit mounting: By T-slots and mounting sets. The linear axis can be combined with any T-slot profile.

Carriage support: In the standard version, the carriage runs on 4 runner blocks which can be adjusted and serviced at a central servicing position. For longer carriages the number of runner blocks can be increased.

Forces and torques	Size	120		160		200	
	permitted dyn. Forces*	5000 km	10000 km	5000 km	10000 km	5000 km	10000 km
F_y (N)		1776	1405	2236	1775	5155	4092
F_z (N)		2090	1650	5278	4189	11311	8977
M_x (Nm)		81	64	282	224	752	597
M_y (Nm)		97	77	283	225	813	646
M_z (Nm)		96	76	300	238	862	684
C (N)		2310		7800		22800	
All forces and torques related to the following:							
existing values $\frac{F_y}{F_{y_{dyn}}} + \frac{F_z}{F_{z_{dyn}}} + \frac{M_x}{M_{x_{dyn}}} + \frac{M_y}{M_{y_{dyn}}} + \frac{M_z}{M_{z_{dyn}}} \leq 1$							
table values $\frac{F_y}{F_{y_{dyn}}} + \frac{F_z}{F_{z_{dyn}}} + \frac{M_x}{M_{x_{dyn}}} + \frac{M_y}{M_{y_{dyn}}} + \frac{M_z}{M_{z_{dyn}}} \leq 1$							
Speed							
(m/sec) max		5		5		5	
Geometrical moments of inertia of aluminium profile							
I_x mm ⁴		5,61x10 ⁵		2,13x10 ⁶		4,81 x10 ⁶	
I_y mm ⁴		34,19x10 ⁵		12,33x10 ⁶		26,0 x10 ⁶	
Elastic modulus N/mm ²		70000		70000		70000	

* referred to life-time

Formula: DSR

Deflection:

$$f = \frac{F \cdot L^3}{E \cdot I \cdot 192}$$

f = deflection (mm)
 F = load (N)
 L = free length (mm)
 E = elastic modulus 70000 (N/mm²)
 I = second moment of area (mm⁴)

Nominal lifetime:

$$L = \left(\frac{C}{F} \right)^3 \times 10^5$$

L = Lifetime in meter
 C = Dynamic load factor (N)
 F = Middle load (N)

Positioning system DSR 120, 160, 200

Dimensions (mm)

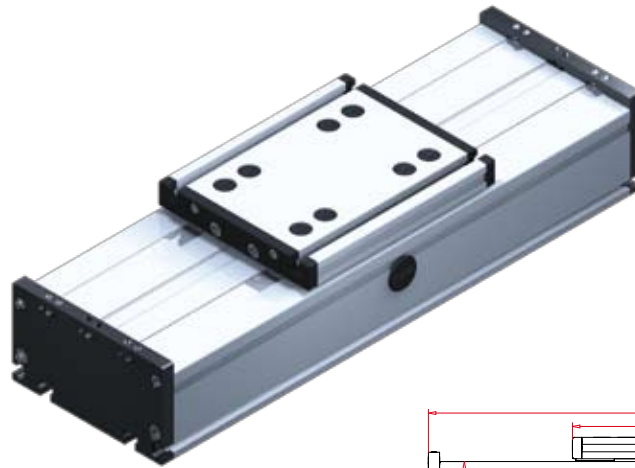
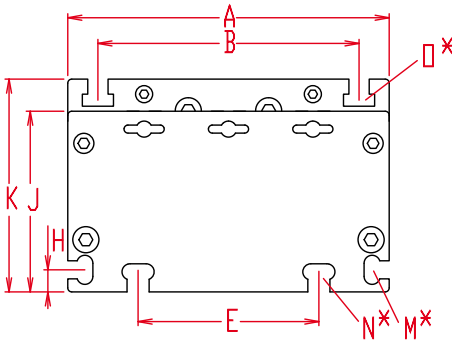

Increasing the carriage length will increase the basic length by the same amount.

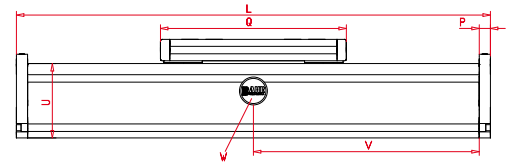

*For slide nuts refer to chapter 2.2 page 2

$V = Q + 100 \text{ mm}$ W = servicing position

Size	Basic length L	A	B	E	H	J	K	M for	N for	O for	P	Q	U	Basic weight	Weight per 100 mm
DSR 120	200	120	96	78	10	68	79	M 5	M 6	M 6	10	156	60	3,2 kg	0,71 kg
DSR 160	240	160	130	90	11	90	106	M 6	M 8	M 8	12	200	80	7,0 kg	1,5 kg
DSR 200	320	200	160	140	15	110	129	M 8	M 10	M 10	15	270	100	15,0 kg	2,9 kg

Choice of guide body profile:

0

(0)

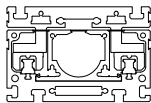

internal profile with cover bands

(1)

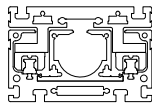

internal profile without cover bands

(2)

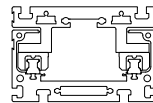

without internal profile and cover bands

(3)



with bellows

Stainless versions upon request.

Choice of carriages:

0

(0)

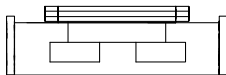

(1)

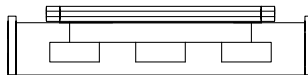

Size	Version 0		Version 1	
	Q	L	Q	L
120	156	200	156	200
160	200	240	>230	>270
200	270	320	>310	>360

1500

Basic length + stroke = total length

DSR 160 0 0 0 0 0 0 0 0 0 1500
Pos. 1 2 3 4 5 6 7

Inductive proximity switch sets, which can be mounted inside of the square profile, are available as accessories. Coupling and a special plug are mounted from the outside. For additional accessories refer to chapter 2.2 - 4.2.



Sample ordering code:

DSR160, with internal profile and cover bands, standard runner blocks, 1260 mm stroke.

8.1