

Linear motor drive

**Function:**

This unit consists of a rectangular aluminium profile with 2 integrated roller guides. The linear motor DLVM unit is based on the principle of a linear, synchronous AC motor.

The guiding profile is fitted with permanent magnets as stator (secondary part). The carriage is fitted with the actuator (primary part). The magnetic attraction causes a force between carriage and guiding profile also in the absence of current. This force can be used for the initial tension of the bearings. Several carriages (primary parts) can be driven independently on one guiding profile.

Fitting position: As required. Max. length 6.000 mm without joints.

Carriage mounting: By T-slots.

Unit mounting: By T-slots and mounting sets. The linear axis can be combined with any T-slot profile.

Carriage support: In the standard version, the carriage runs on 8 rollers which can be adjusted and serviced at a central servicing position. For longer carriages the number of rollers can be increased.
Repeatability $\pm 0,05$ mm. Repeated accuracy max. $\pm 0,05$ bis 4.000 mm, $\pm 0,1$ >4.000 mm.

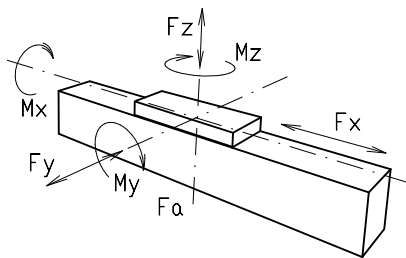
Forces and torques

- F_z = external force by load
 F_a = magnetic attraction force
 F_{zm} = maximum force in consideration of motor power
 $F_{zm} = F_z + F_a$

Size	200
Motor size	3
Forces/Torques	
F_{zdyn} (N)	11000
F_{zmm} (N)	13800
F_y (N)	1200
M_x (Nm)	220
M_y (Nm)	230
M_z (Nm)	210
Number of rollers	12
All forces and torques related to the following:	
existing values	$\frac{F_y}{F_{y_{dyn}}} + \frac{F_{zm}}{F_{zm_{dyn}}} + \frac{M_x}{M_{x_{dyn}}} + \frac{M_y}{M_{y_{dyn}}} + \frac{M_z}{M_{z_{dyn}}} \leq 1,5$
table values	
Motor specifications F_x	
Motor size	3
Carriage weight (kg)	12,7
Weight primary part (kg)	8,4
permanent (N)	766
Max. (N) (1 sek.)	1735
Moving force without current	
N	12
Speed	
(m/sec) max	6
Geometrical moments of inertia of aluminium profile	
I_x mm ⁴	$6,38 \times 10^6$
I_y mm ⁴	$33,5 \times 10^6$
Elastic modulus N/mm ²	70000

For life-time calculation of rollers use our CD-ROM or homepage!

Formula: DLVM

$$f = \frac{F \cdot L^3}{E \cdot I \cdot 192}$$

f = deflection (mm)
 F = load (N)
 L = free length (mm)
 E = elastic modulus 70000 (N/mm²)
 I = second moment of area (mm⁴)

Positioning system DLVM 200

Dimensions (mm)

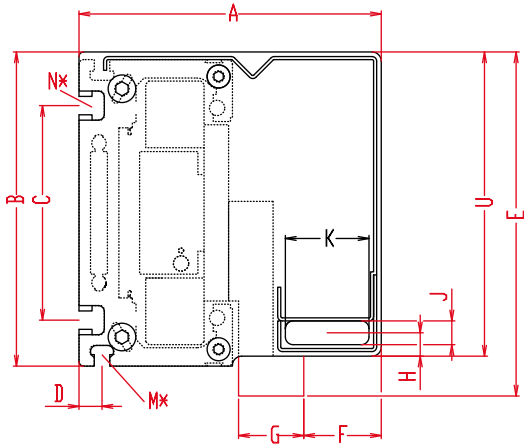

Increasing the carriage length will increase the basic length by the same amount.

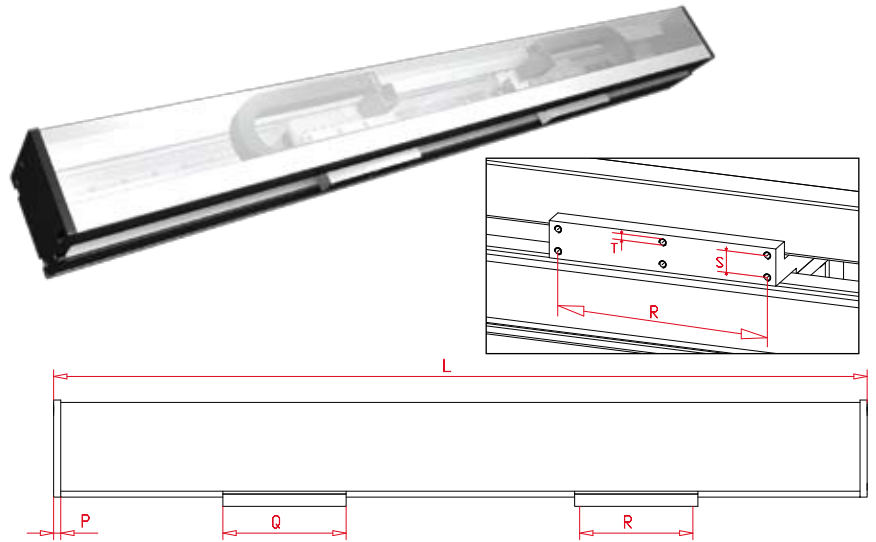

*For slide nuts refer to chapter 2.2 page 2

Size	Basic length L	A	B	C	D	E	F	G	H	J	K	M for	N for	P	Q	R	S	T for	U	Basic weight	Weight per 100 mm
DLVM 200	602	197	205	140	15	224,5	50,5	42,5	15	15,5	54,5	M 8	M10	15	260	240	25	M8	198,5	39,4 kg	2,8 kg

1500

Basic length + stroke = total length

DLVM 200 0 0 0 0 0 0 1 01500

Pos. 1 2 3 4 5 6 7

Sample ordering code:

DLVM200, 898 mm stroke.

