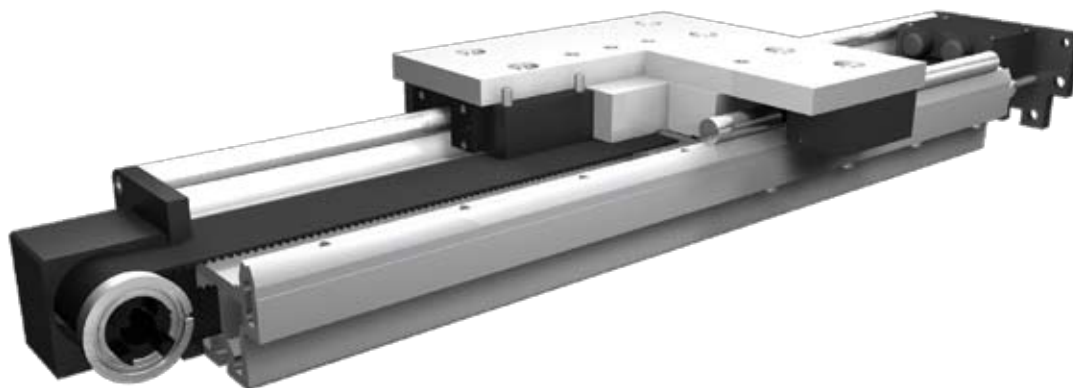

## Belt drive

**Function:**

This unit consists of an aluminium profile with hardened steel guide rods mounted on top of the profile. The carriage, which has internal linear ball bearings that can be adjusted free of play, is driven along the guide rods by a timing belt. The pulleys have maintenance-free ball bearings. Opposite the driven side there is an integrated timing-belt tensioner which can be readjusted by 2 screws.

**Fitting position:**

As required. Max. length 6.400 mm without joints.

**Carriage mounting:**

By tapped holes.

**Unit mounting:**

By T-slots and mounting sets. The linear axis can be combined with any T-slot profile.

**Carriage support:**

In the standard version, the carriage runs on 8 rollers which can be adjusted and serviced at a central servicing position. For longer carriages the number of rollers can be increased.

Repeatability  $\pm 0,1$ .

**Belt type:**

HTD with steel reinforcement, no backlash when changing direction, repeatability:  $\pm 0,1$  mm.

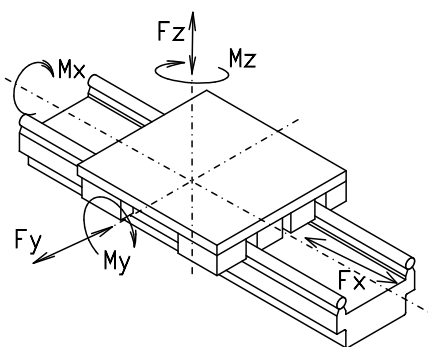
**Forces and torques**

Size	ALLZ 203		ALLZ 204	
	static	dynamic	static	dynamic
<b>Forces/Torques</b>				
$F_z$ (N)	-	5610	-	5610
$F_y$ (N)	23000	18400	30000	24000
$F_x$ (N)	11000	8800	16200	13000
$M_x$ (Nm)	1180	950	1870	1500
$M_y$ (Nm)	1870	1500	3000	2400
$M_z$ (Nm)	3800	3100	5600	4500
<b>All forces and torques related to the following:</b>				
existing values $\frac{F_y}{F_{y_{dyn}}} + \frac{F_z}{F_{z_{dyn}}} + \frac{M_x}{M_{x_{dyn}}} + \frac{M_y}{M_{y_{dyn}}} + \frac{M_z}{M_{z_{dyn}}} \leq 1$				
table values $\frac{F_y}{F_{y_{dyn}}} + \frac{F_z}{F_{z_{dyn}}} + \frac{M_x}{M_{x_{dyn}}} + \frac{M_y}{M_{y_{dyn}}} + \frac{M_z}{M_{z_{dyn}}} \leq 1$				
<b>No-load torque</b>				
Nm	4		4	
<b>Speed</b>				
(m/sec) max	8		8	
<b>Geometrical moments of inertia of aluminium profile</b>				
$I_x$ mm <sup>4</sup>	$2,26 \times 10^7$		$2,98 \times 10^7$	
$I_y$ mm <sup>4</sup>	$8,75 \times 10^7$		$10,22 \times 10^7$	
Elastic modulus N/mm <sup>2</sup>	70000		70000	

**Formula: ALLZ**

Driving torque:

$$M_o = \frac{F \cdot P \cdot S_1}{2000 \cdot \pi} + M_{leer}$$

$$P_o = \frac{M_o \cdot n}{9550}$$

F	= force	(N)
P	= pulley action perimeter	(mm)
$S_1$	= safety factor 1,2 ... 2	
$M_{leer}$	= no-load torque	(Nm)
n	= rpm pulley	(min <sup>-1</sup> )
$M_o$	= driving torque	(Nm)
$P_o$	= motor power	(KW)

$$f = \frac{F \cdot L^3}{E \cdot I \cdot 192}$$

f	= deflection	(mm)
F	= load	(N)
L	= free length	(mm)
E	= elastic modulus 70000	(N/mm <sup>2</sup> )
I	= second moment of area	(mm <sup>4</sup> )

# Positioning system ALLZ 203, 204

Dimensions (mm)

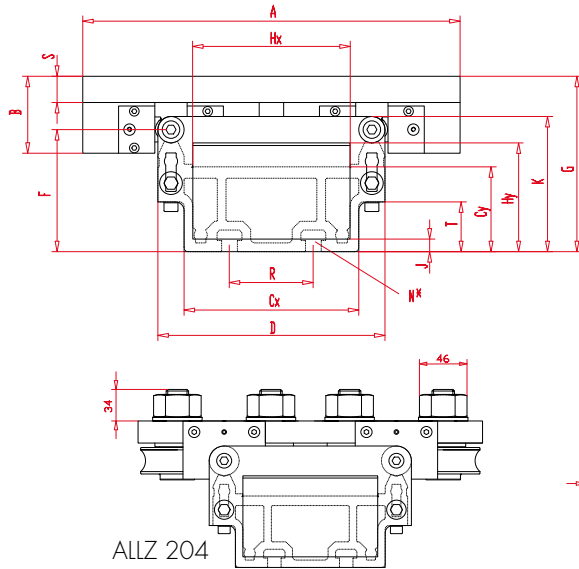

Increasing the carriage length will increase the basic length by the same amount.

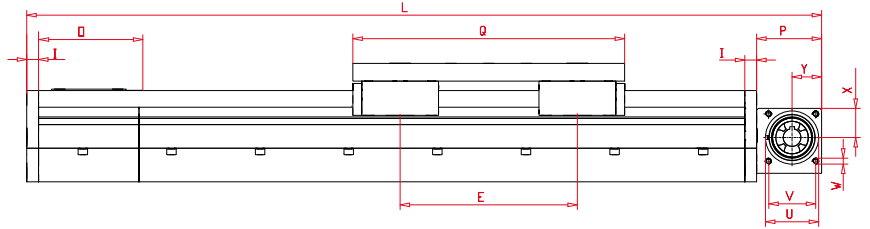

Size □	Basic length L	A	B	Cx	Cy	D	E	F	G	Hx	Hy	I	J	K	N for	O	P	Q	R	S	T	U	V	W	X	Y	Basic weight	Weight per 100 mm
ALLZ 203	792	432	88	200	97	260	300	140	200,5	180,5	124,5	20	14,5	154,5	M16	182	110	460	96	30	57	90	80	10	49,5	50	90 kg	4,0 kg
ALLZ 204	822	460	80	200	97	270	355	145	199	180,5	124,5	20	14,5	165	M16	182	110	490	96	30	57	90	80	10	49,5	50	92 kg	4,9 kg

**3** Guide rod size:  
(3) Ø=30 (4) Ø=40

**0** Choice of guide body profile:  
(0) Standard (2) corrosion-protected guide rods and screws  
(4) expanded corrosion-protected version (depending on the availability of components)

**0** Drive version:

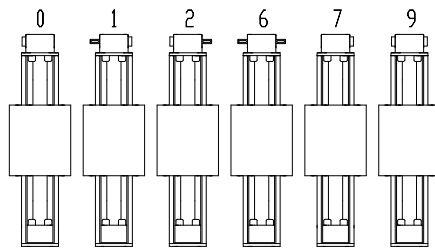

9 is as 0, but with coupling claws on both sides.

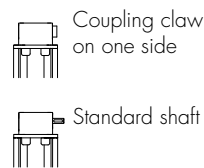

The standard version is supplied without shaft. A shaft can be retrofitted by inserting it into the pulley bore and securing it with 2 locking rings.

**Belt table**

Code No.	Belt	mm/rev.	Number of teeth
0 7	8M100	224	28

Size	Shaft ø h6 x length	Key
203	30 x 55	8x7x50
204	30 x 55	8x7x50

Basic length + stroke = total length

ALLZ 20	3	0	0	0	0	0	7	0	2000
Pos.	1	2	3	4	5	6	7		

Sample ordering code:  
ALLZ203, guide rods 30 mm, standard body profile, coupling claw on both side, toothed belt 8M100, 1208 mm stroke.

**10.1**

