

# Positioning system ALLR 203, 204

## Roller guide unit without drive

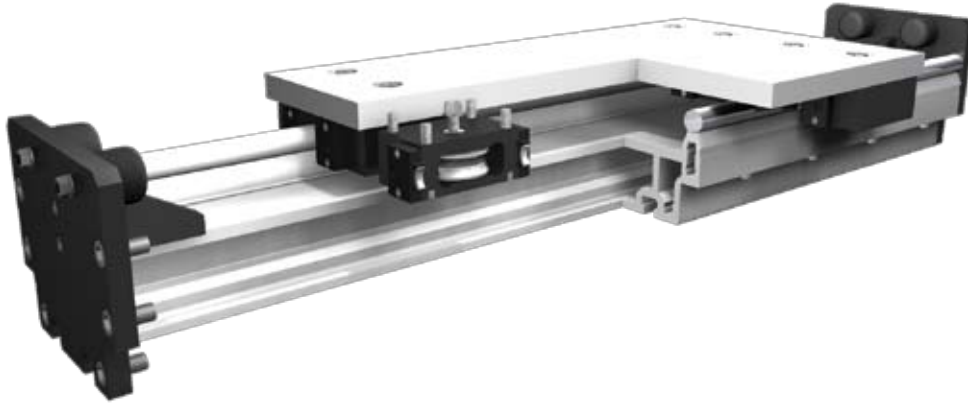

### Function:

This unit consists of an aluminium profile with hardened steel spindles mounted on top of the profile. The carriage has internal linear ball bearings that can be adjusted free of play. The unit is without drive.

### Fitting position:

As required. Max. length 6.400 mm without joints.

### Carriage mounting:

By tapped holes.

### Unit mounting:

By T-slots and mounting sets. The linear axis can be combined with any T-slot profile.

### Carriage support:

In the standard version, the carriage runs on 8 rollers which can be adjusted and serviced at a central servicing position. For longer carriages the number of rollers can be increased.

### Forces and torques

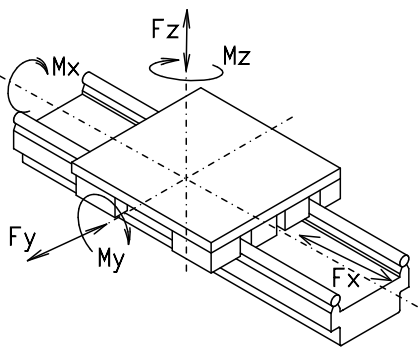

Size	ALLR 203		ALLR 204	
	static	dynamic	static	dynamic
<b>Forces/Torques</b>				
$F_v$ (N)	23000	18400	30000	24000
$F_z$ (N)	11000	8800	16250	13000
$M_x$ (Nm)	1200	950	1870	1500
$M_y$ (Nm)	1870	1500	3000	2400
$M_z$ (Nm)	3800	3100	5600	4500
<b>All forces and torques related to the following:</b>				
existing values $\frac{F_y}{F_{y_{dyn}}} + \frac{F_z}{F_{z_{dyn}}} + \frac{M_x}{M_{x_{dyn}}} + \frac{M_y}{M_{y_{dyn}}} + \frac{M_z}{M_{z_{dyn}}} \leq 1$				
table values				
<b>Geometrical moments of inertia of aluminium profile</b>				
$I_x$ mm <sup>4</sup>	2,26 x 10 <sup>7</sup>		2,98 x 10 <sup>7</sup>	
$I_y$ mm <sup>4</sup>	8,75 x 10 <sup>7</sup>		10,22 x 10 <sup>7</sup>	
Elastic modulus N/mm <sup>2</sup>	70000		70000	

### Formula: ALLR

$$f = \frac{F \cdot L^3}{E \cdot I \cdot 192}$$

$f$  = deflection (mm)  
 $F$  = load (N)  
 $L$  = free length (mm)  
 $E$  = elastic modulus 70000 (N/mm<sup>2</sup>)  
 $I$  = second moment of area (mm<sup>4</sup>)

# Positioning system ALLR 203, 204

Dimensions (mm)

Increasing the carriage length will increase the basic length by the same amount.

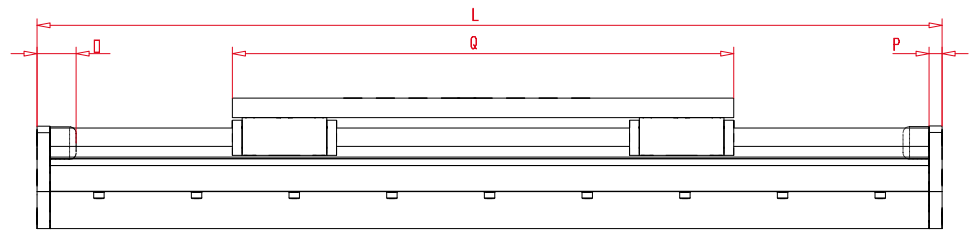
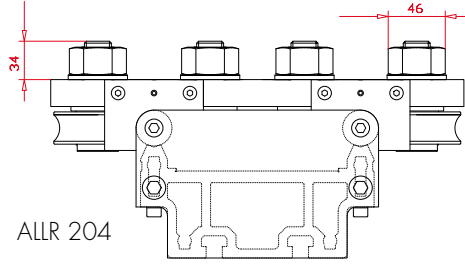
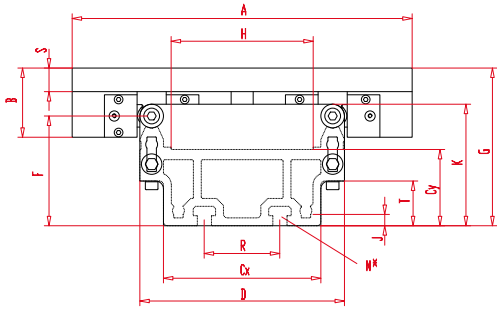

Size □	Basic length L	A	B	Cx	Cy	D	F	G	H	K	N for	O	P	Q	R	S	T	Basic weight	Weight per 100 mm
ALLR 203	580	432	88	200	97	260	139,6	200,5	180,5	154,5	M16	60	20	460	96	30	57	64 kg	3,9 kg
ALLR 204	610	460	80	200	97	270	139,6	199	180,5	165	M16	60	20	490	96	30	57	65 kg	4,8 kg

- 3** Guide rod size  
(3) Ø=30 (4) Ø=40
- 0** Choice of guide body profile:  
(0) Standard (2) corrosion-protected guide rods and screws  
(4) expanded corrosion-protected version (depending on the availability of components)

Basic length + stroke = total length

ALLR20 3 0 0 0 0 0 0 0 2000

Pos. 1 2 3 4 5 6 7

Sample ordering code:  
ALLR203, guide rods 30 mm, standard body profile, 1420 mm stroke.

