

# Anfrage 1-Achssystem/Inquiry 1-direction system

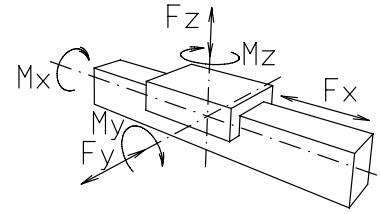

Firma/Company		Name	
Tel/Fax		Zykluszeit/Cycle time	s
Hub/Stroke	mm m	kg	<b>Motore, Steuerung/Motors, Controllers</b>
Genauigkeit/Repeatability	mm	Angebot/Offer	ja <input type="checkbox"/> yes nein <input type="checkbox"/> no
Geschwindigkeit/Velocity	m/s	Schrittmotor/Steppingmotor	<input type="checkbox"/>
Beschleunigung/Acceleration	m/s <sup>2</sup>	Servo	<input type="checkbox"/>
Horizontal	<input type="checkbox"/>	Drehstrom/AC	<input type="checkbox"/>
Vertikal	<input type="checkbox"/>	Gleichstrom/DC	<input type="checkbox"/>

1	2	3
---	---	---

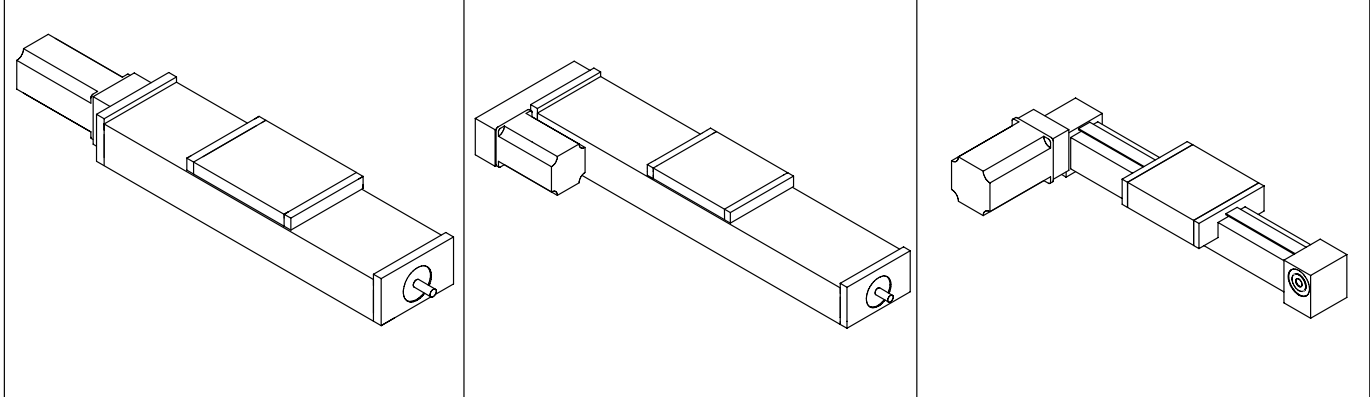

4	5	6
---	---	---

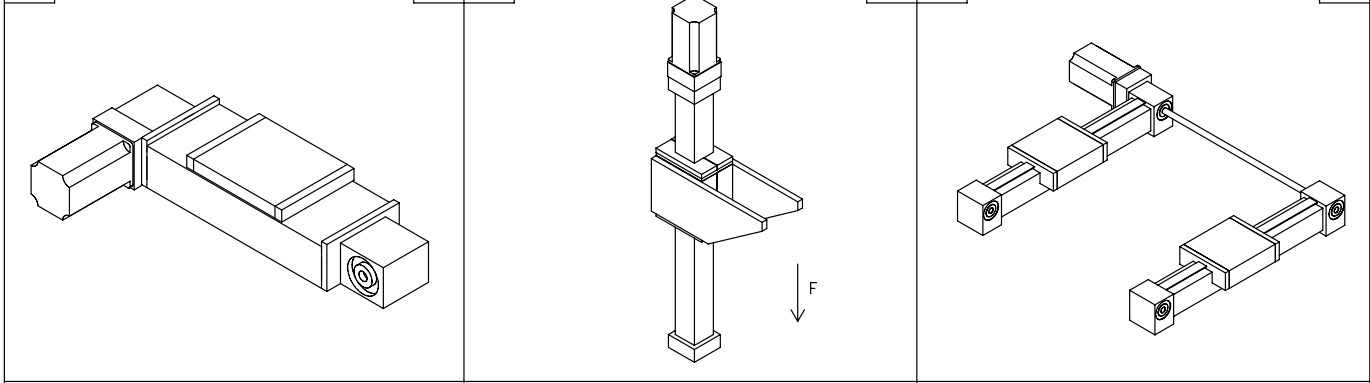

7	8	9
---	---	---

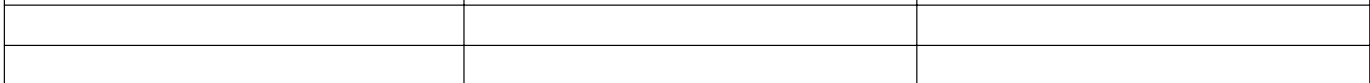
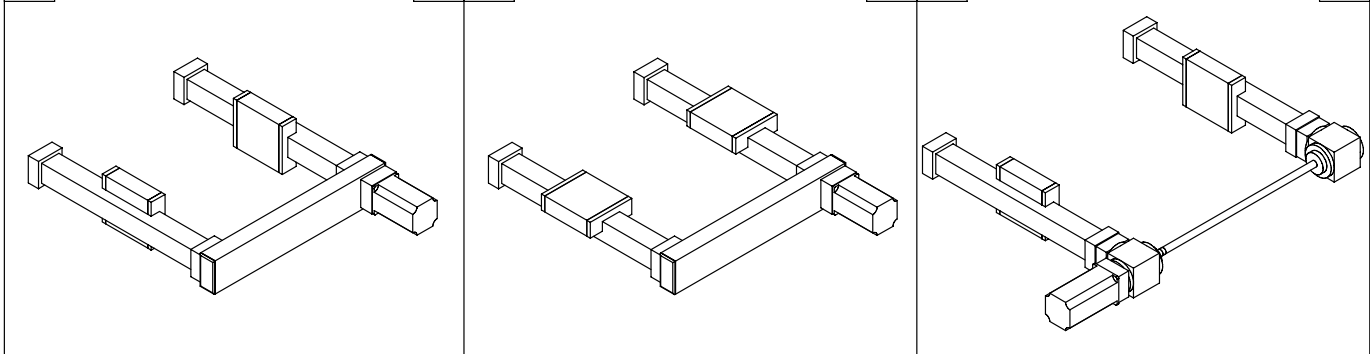

## Anfrage 2-Achssystem/Inquiry 2-direction system

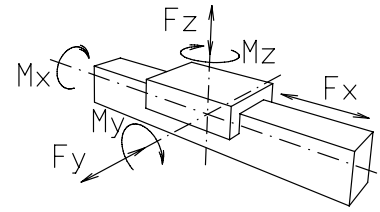

Firma/Company		Name	
Tel/Fax		Zykluszeit/Cycle time	s
Masse/Mass		kg	<b>Motore, Steuerung/Motors, Controllers</b>

	Hub/Stroke(mm)	a(m/s <sup>2</sup> )	v(m/s)	Angebot/Offer	ja <input type="checkbox"/> yes	nein <input type="checkbox"/> no
X				Schrittmotor/Steppingmotor	<input type="checkbox"/>	
Y				Servo	<input type="checkbox"/>	X
Z				Drehstrom/AC	<input type="checkbox"/>	Y
Drehachse/Rotation axis			1/min	Gleichstrom/DC	<input type="checkbox"/>	Z

Kräfte/Force	Momente/Torques
X N	Nm
Y N	Nm
Z N	Nm

1		2		3	
---	--	---	--	---	--

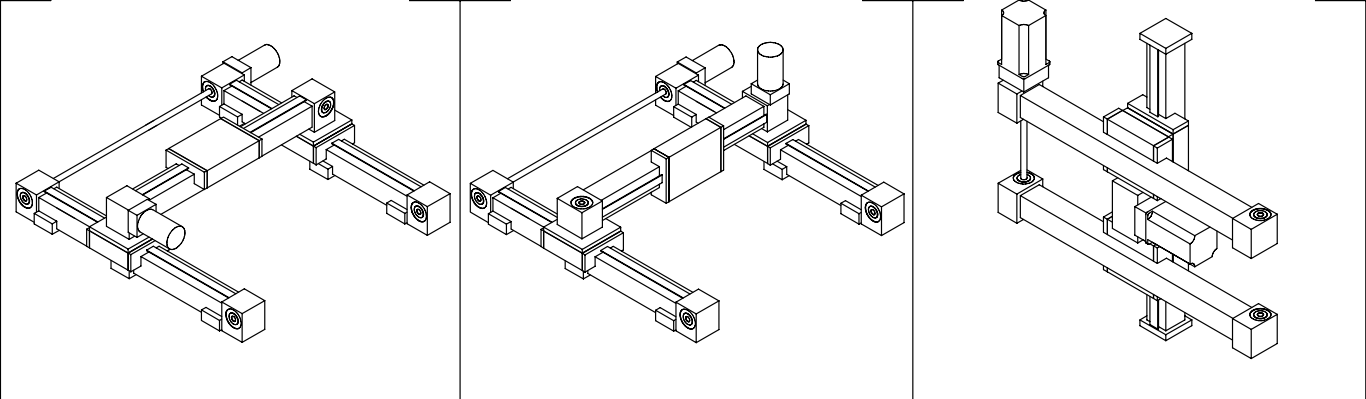

4		5		6	
---	--	---	--	---	--

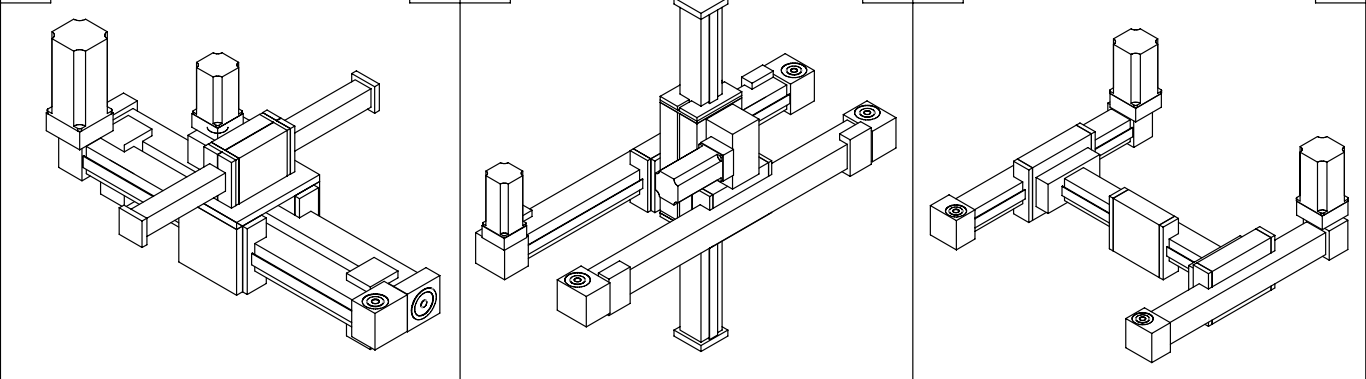

7		8		9	
---	--	---	--	---	--

